

SPINVISTA SPIN WINDOWS

SPINVISTA Spin Windows are suitable for all types of CNC milling machines, lathes and machining centres, either retro-fitted or integrated at the factory.



Direct view of the machining process in the machine

The SPINVISTA can be installed both as part of the original OEM equipment and as part of the retrofitting. Work ergonomics and productivity are significantly improved by the generous view of the actual machining process in the machine without impairment of visibility by coolants or swarf.

The light weight, the simple assembly and the optimal maintenance due to the modular design reduce the costs for assembly and maintenance. Complete solutions - machine windows with built-in SPINVISTA spin windows are also available. There is no additional installation effort here. The systems can be pre-configured in such a way that they only have to be installed and connected. All systems meet the respective security requirements.

SPINVISTA Spin windows types EVO and NEO

The SPINVISTA Spin window is available in two versions, which differ in the size of the visible surface:

- **SPINVISTA EVO:** Ideal for replacing already assembled systems in the event of a defect or upgrade, 1: 1 compatible with existing assembly systems from HEMA
- **SPINVISTA NEO:** Larger field of vision with proven functionality

Advantages of SPINVISTA Spin Windows

SPINVISTA is synonymous with active safety precautions: Without SPINVISTA, the operator can be tempted to bypass the safety circuit of the machine to see what is happening in the machine - potential danger with serious consequences! With regard to product liability and safety regulations, take a look at the safety advantages of SPINVISTA - it could pay off.

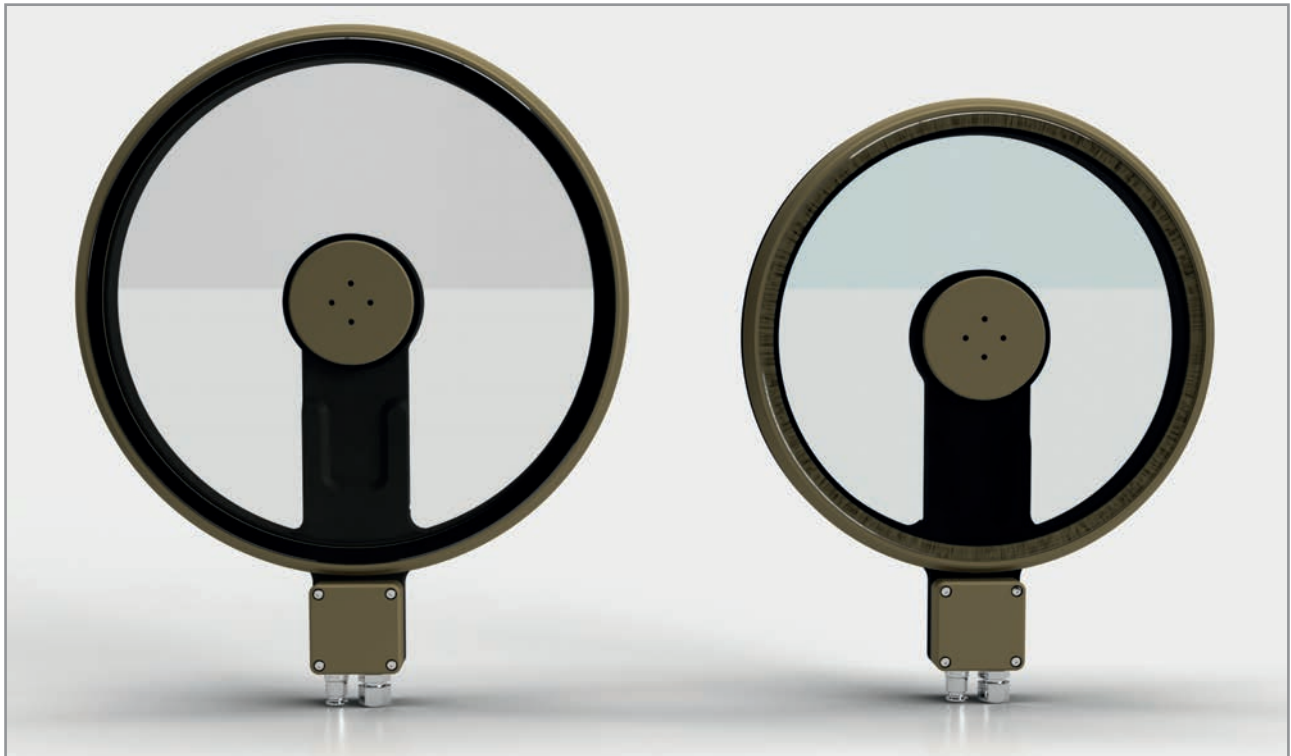

SPINVISTA NEO und SPINVISTA EVO

SPINVISTA SPIN WINDOWS

03

CONTENT

04

SAFETY
WINDOWS

12

SPINVISTA
SPIN WINDOWS

Installation and fixing

No hole has to be drilled in the machine cabin. The unit is either fastened on the bonded mounting plate or bonded directly to the window. The SPINVISTA is either screwed onto the mounting plate or bonded directly onto the safety window. The mounting plate allows fast replacement of the SPINVISTA.

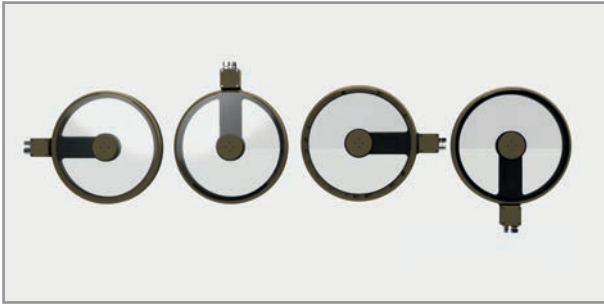

Variable mounting, any position at an angle of 0° - 360° possible

The SPINVISTA can be mounted on the machine safety disc in any position rotated from 0° to 360° with a vertical inclination of up to 5° . The power can be supplied in three positions.

It can be installed in the operator's door as well as in a »fixed« window. The flat design with a total height of <32 mm means that it can be easily adapted to a wide variety of door and window designs. If there is enough space, it can also be attached to sliding doors.

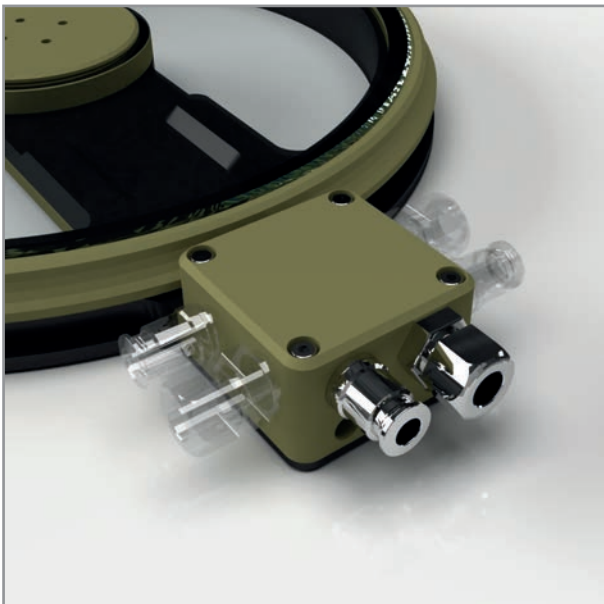

Mounting positions of the power supply

SPINVISTA can be fixed in different ways:

- bonded
- screwed to safety window
- screwed directly to the integrated mounting plate

Bonding

The SPINVISTA is mounted easily with a high-tech adhesive sheet (adhesive based on closed cellular acrylic foam). Simply remove the protective foil on the rear side of the SPINVISTA and bond the SPINVISTA to the desired position on the pane which should be cleaned thoroughly beforehand. The optimal setting time is 72 hours. To speed up installation we offer a special vacuum pump, which reduces the bonding time to 1-2 hours (95% bonding strength). Applying heat to the mounting frame can also help to reduce the bonding time. Afterwards it is very difficult to separate the SPINVISTA from the surface it is bonded to, provided the surface had been cleaned adequately beforehand.

Machine safety windows with integrated mounting plate

The easiest solution is to secure the SPINVISTA to the mounting plate already integrated within the safety window. SPINVISTA only has to be positioned and secured in place with the enclosed screws.

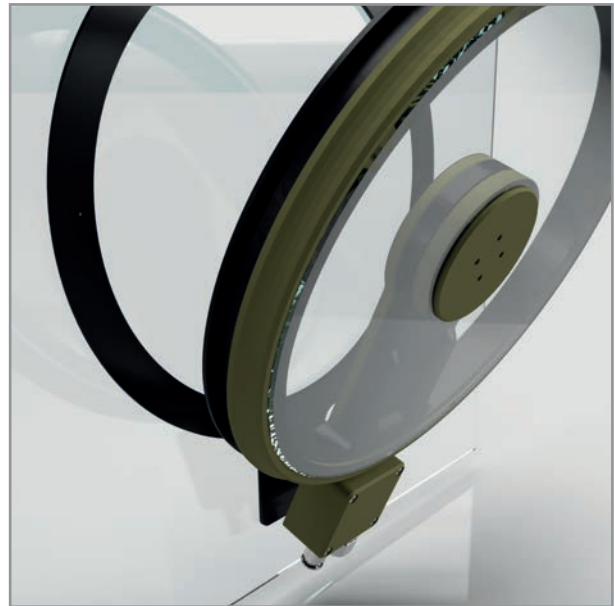

Machine safety window with mounting plate

Screwed to safety window

In this case six holes are drilled through the polycarbonate pane (a process that degrades the pane's resistance). The holes are sealed from the machine's cabin side with an integrated o-ring. On the control side SPINVISTA is fixed in place with a screwed clamping flange

SPINVISTA SPIN WINDOWS

| Model | SPINVISTA EVO | SPINVISTA NEO |
|----------------------------|---|---|
| Application | Milling centers, lathes and grinding machines | Milling centers, lathes and grinding machines |
| Operating temperatur | 10 ° C ... + 50 ° C permissible | 10 ° C ... + 50 ° C permissible |
| Dimensions | Ø 253 mm / 253 x 321 x 31,6 mm | Ø 290 mm / 290 x 358 x 31,6 mm |
| Inner diameter | Ø 216 mm | Ø 253 mm |
| Field of view | 284 cm ² | 430 cm ² |
| Nominal voltage | 24 VDC ± 3V | 24 VDC ± 3V |
| Nominal current | 0.5 A (starting current 3.5 A / 24 VDC) | 0.5 A (starting current 3.5 A / 24 VDC) |
| Power consumption | Idle approx. 12 W (24 V, 500 mA) | Idle approx. 12 W (24 V, 500 mA) |
| Rated speed | 2.300 U/min | 2.300 U/min |
| Weight | 1.8 kg | 2.1 kg |
| Noise emissionn | <65 dB (A) DIN EN ISO 11200 | <65 dB (A) DIN EN ISO 11200 |
| Overpressure / sealing air | min. 20 - 50 mbar (optional) | min. 20 - 50 mbar (optional) |
| Air consumption | ~ 1.1m ³ /h (at 20 mbar) | ~ 1,1m ³ /h (at 20 mbar) |
| Air purity | ISO 8573-1: 2010 [3: 4: 3] required | ISO 8573-1: 2010 [3: 4: 3] required |
| Mounting | Maximum inclination angle of disc 5° Orientation of connection as required | Maximum inclination angle of disc 5° Orientation of connection as required |
| Motor | Brushless with blocking and reverse polarity protection | Brushless with blocking and reverse polarity protection |

CONTENT 03

SAFETY WINDOWS 04

SPINVISTA SPIN WINDOWS 13

Coolant

SPINVISTA functions best with water based coolants and mineral oils; other oils on request.

Product quality

The basic components are made of high quality aluminum with a hard anodized surface. The electronic components were specially developed for the SPINVISTA and are fully encapsulated and protected against moisture. All parts and components of the SPINVISTA are checked for material quality and service life.



Connection possibilities, example G1/4

SPINVISTA EVO

03

CONTENT

04

SAFETY
WINDOWS

14

SPINVISTA
SPIN WINDOWS

SPINVISTA EVO Spin window

- Spinning disk mounted in the machine side, providing a clear view of the process through its high rotary speed (> 2,300 rpm)
- Viewing area 284 cm²
- Integrated, fully encapsulated control electronics with reverse polarity protection, thermal protection against overheating (150°C)
- Integrated brushless DC motor 24V (± 1V) DC, fully encapsulated
- fulfils CE standards for low tension voltage
- low weight, only about 1.8 kg
- built-in chip protection with specially designed base and disc ring

Connection variants

The SPINVISTA EVO has two connection openings on the base of the device, three connection variants are possible:

Variant A

Connection 1: Screw connection base to FLEX metal wire hose or M12x1.5 cable screw connection

Connection 2: Push-in fitting G1 / 8 for hoses 8 mm or push-in fitting G1 / 8 for hoses 6 mm or G1 / 8 blind plugs



SPINVISTA EVO

Variant B

Connection 1: Connection plug M12

Connection 2: Push-in fitting G1 / 8 for hoses 6 mm

Variant C

G1 / 4 connection box with EO pipe connection for metal pipes with Ø 8, 10 or 12 mm

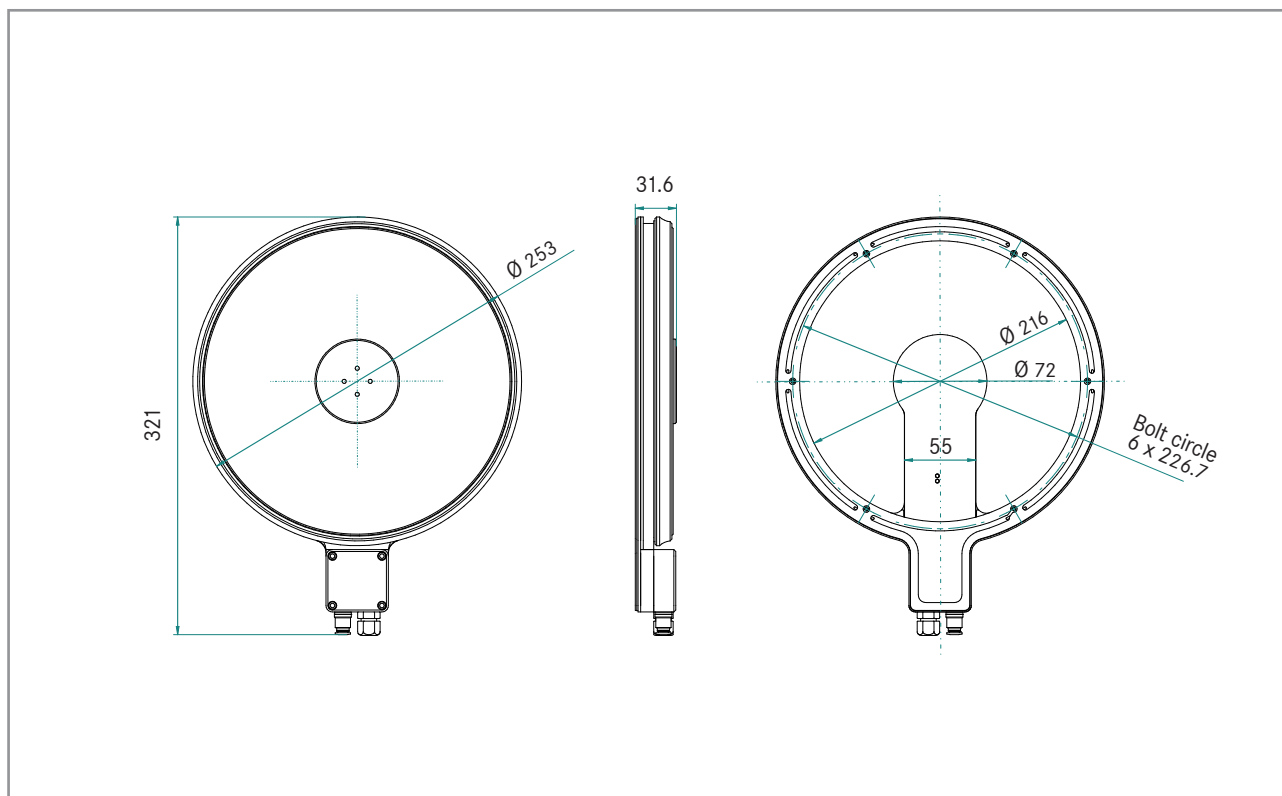

SPINVISTA EVO

SPINVISTA NEO

SPINVISTA NEO Spin window

- Spinning disk mounted in the machine side, providing a clear view of the process through its high rotary speed (> 2,300 rpm)
- Viewing area 410 cm²
- Integrated, fully encapsulated control electronics with reverse polarity protection, thermal protection against overheating (150°C)
- Integrated brushless DC motor 24V (± 1V) DC, fully encapsulated
- fulfils CE standards for low tension voltage
- low weight, only about 2.1 kg
- built-in chip protection with specially designed base and disc ring

Connection variants

The SPINVISTA EVO has two connection openings on the base of the device, three connection variants are possible:

Variant A

- Connection 1: Screw connection base to FLEX metal wire hose or M12x1.5 cable screw connection
- Connection 2: Push-in fitting G1 / 8 for hoses 8 mm or push-in fitting G1 / 8 for hoses 6 mm or G1 / 8 blind plugs



SPINVISTA NEO

Variant B

- Connection 1: Connection plug M12
- Connection 2: Push-in fitting G1 / 8 for hoses 6 mm

Variant C

- G1/4 connection box with EO pipe connection for metal pipes with Ø 8, 10 or 12 mm Ø 8, 10 oder 12 mm

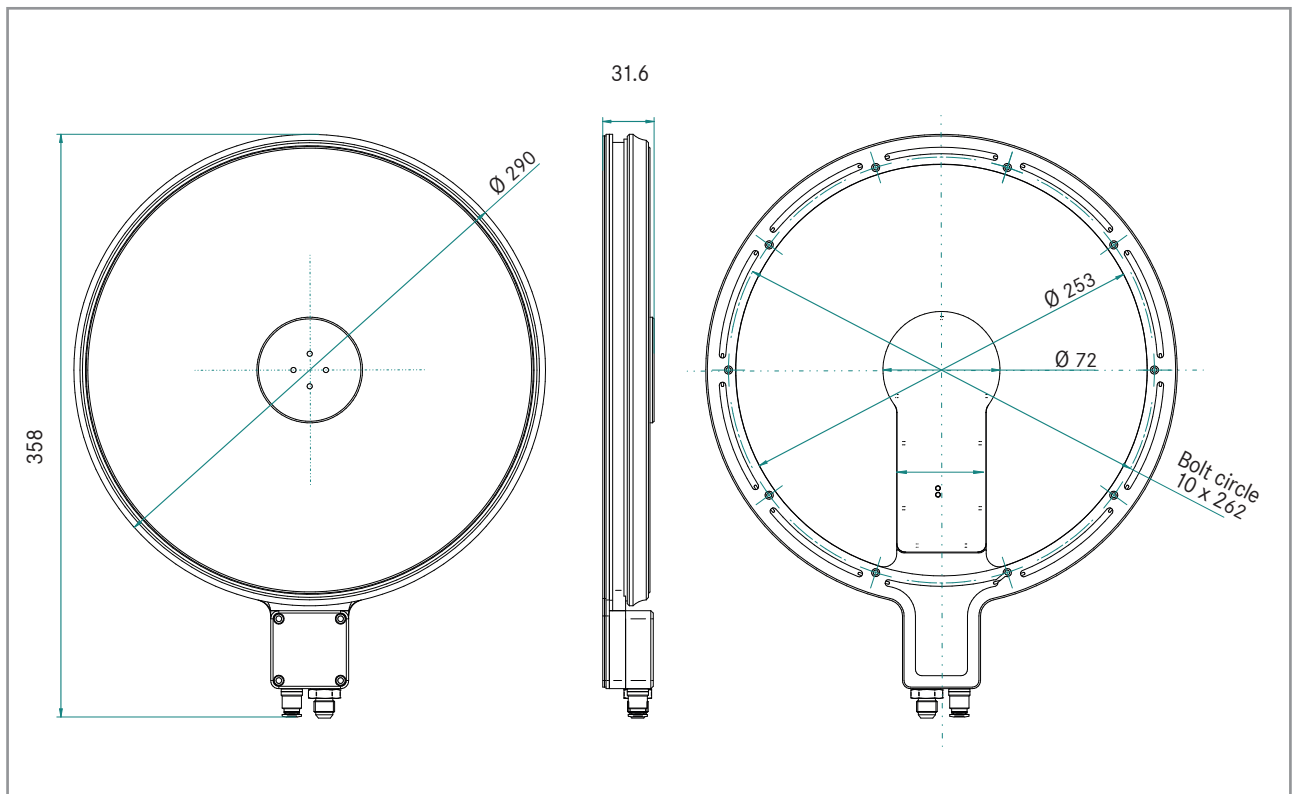

SPINVISTA NEO